

Superuse

Eric Peters

- Superuse staat voor....
- “Listen to the Material”
- Vragen



Superuse

Superuse ontwerpt al 25 jaar waardevolle plaatsten om te zijn, te ontmoeten en te werken.

- Realisatie van (niet alleen bouw-) **materiaal gedreven**, lage voetprint ontwerpen.
- Advies en hulp aan vastgoedeigenaren, architecten en bouwers.
- Ontwikkeling van methodes en instrumenten om realisatie te faciliteren.
- Groot, betrouwbaar netwerk.
- Ontwikkeling van innovatieve bouwmaterialen.



Waarom en hoe?

Duurzaam bouwen zeer legitiem maar complex.

Door dit wel te doen leidt je je organisatie op voor de toekomst.

Ontwerp- en materiaal strategie nodig.

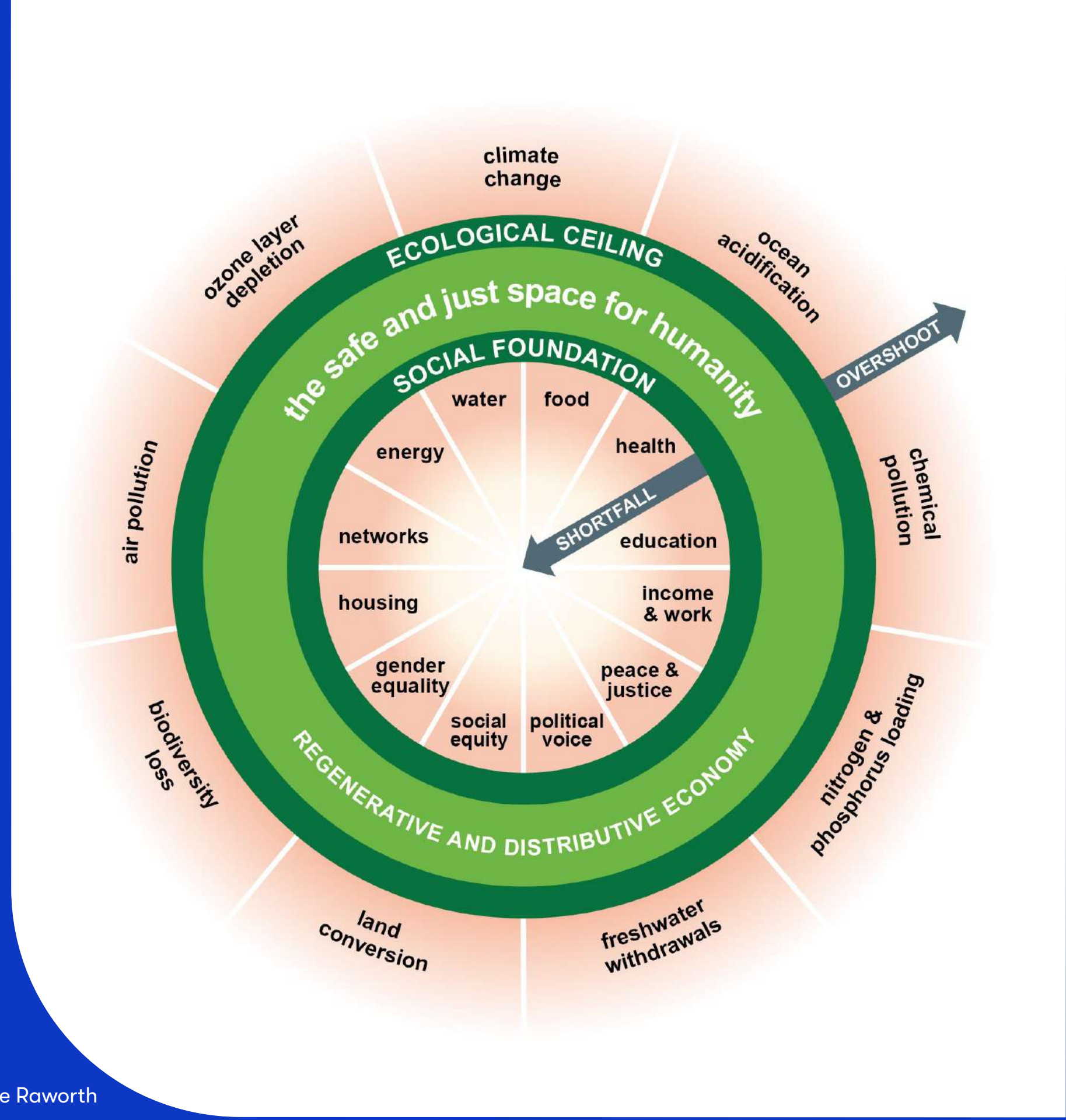

Material strategy

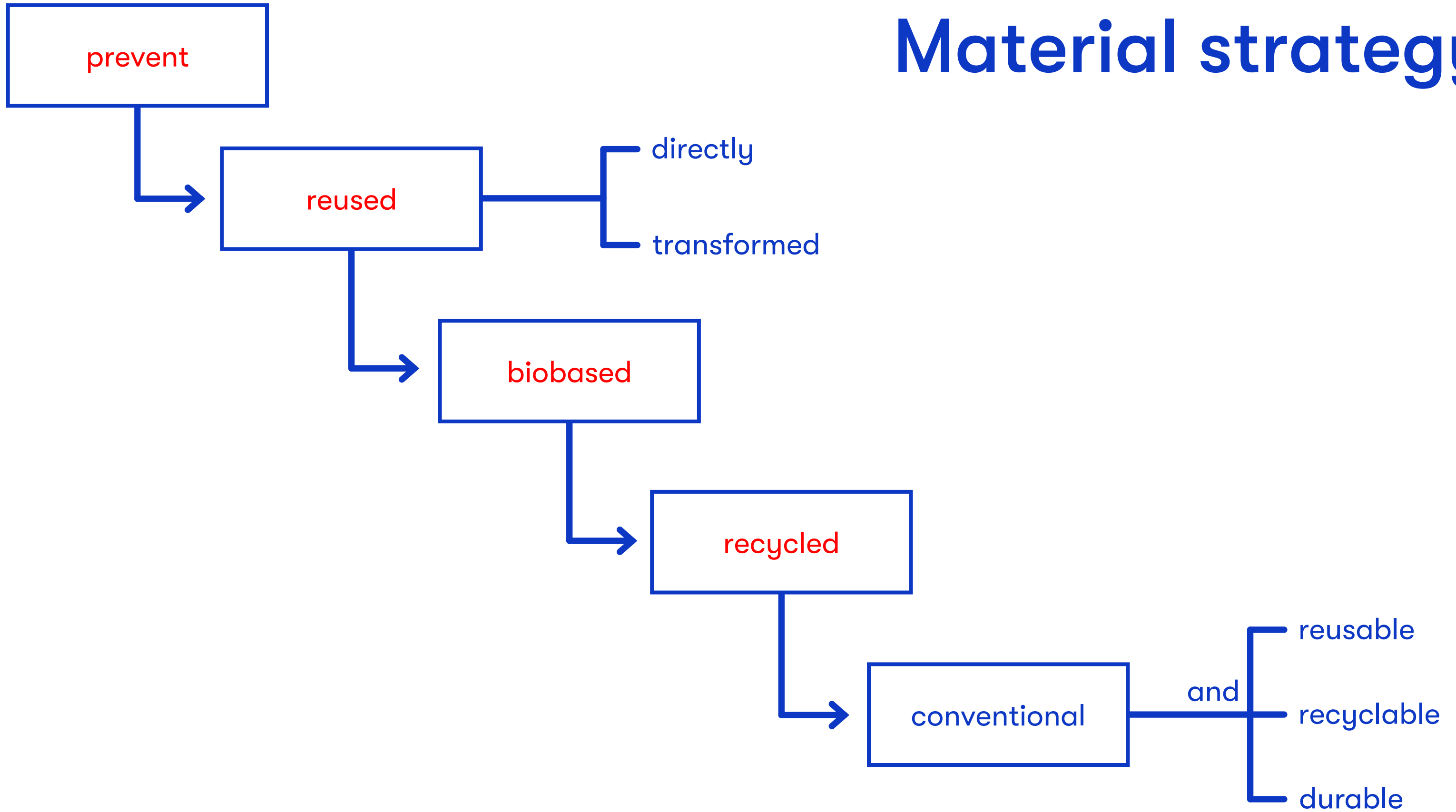

SUPERUSE

of:

- Dead stock
- Construction or demolition waste
- Fast life waste
- Production waste
- End of Life

SUPERUSE

Dead stock

— Out-dated material that is no longer manufactured or no longer has repair or technical support.



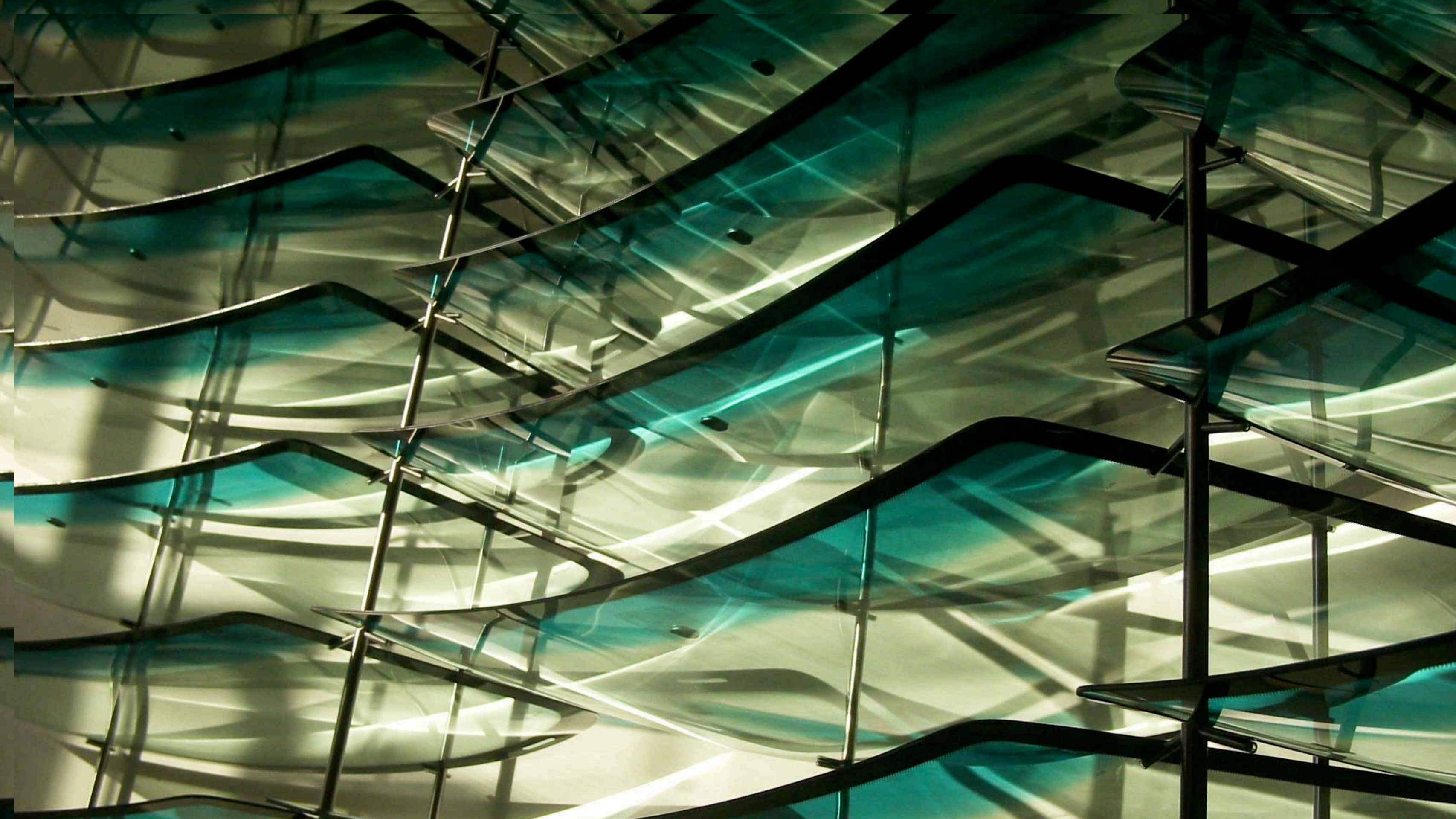

SUPERUSE

Construction or demolition waste

— Material from construction, renovation and/or demolition projects.

Villa Welpelooc

A modern house for an art collecting couple





01



+0 km
bouwlift

02



+15 km
kabelhaspel-
latjes

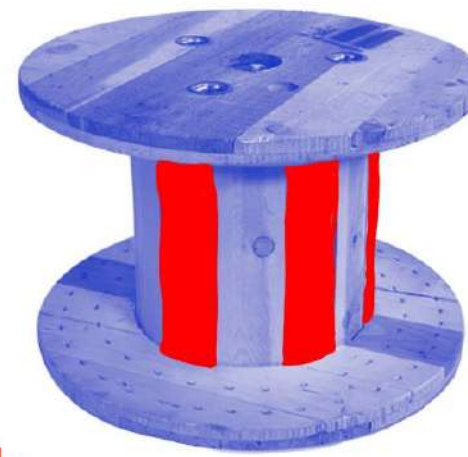

Villa Wepeloo Enschede

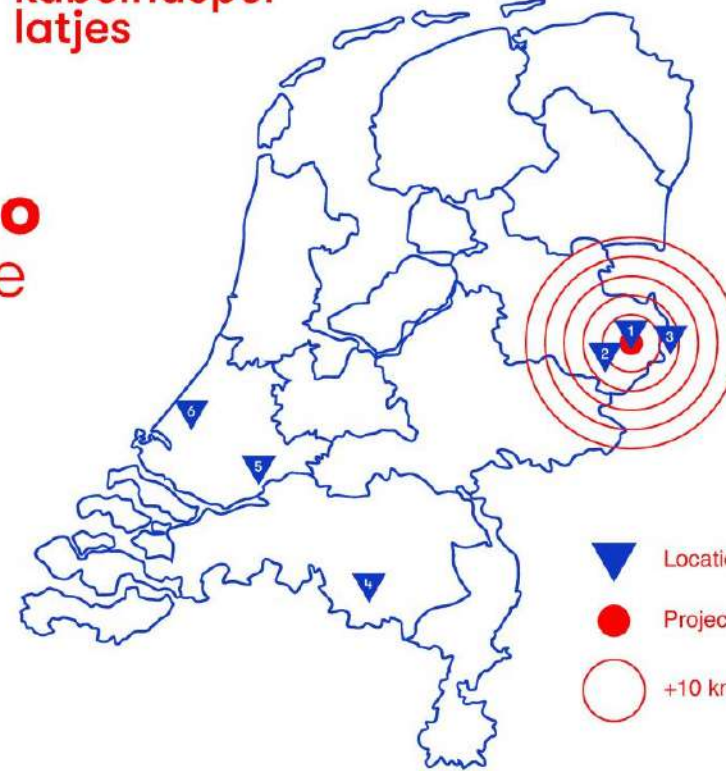

- ▼ Locatie
- Project
- +10 km



03

+15 km
staal van
textielmachine

06

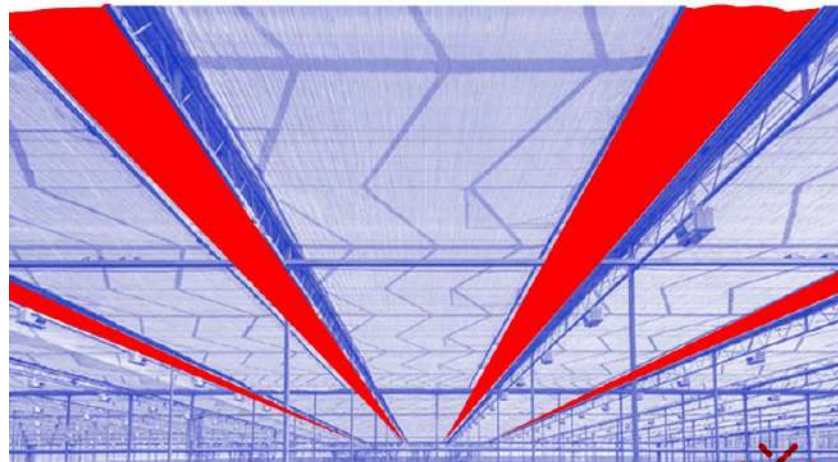

+234 km
kassendoeken



05

+186 km
bouwborden



04

+167 km
contourplaten

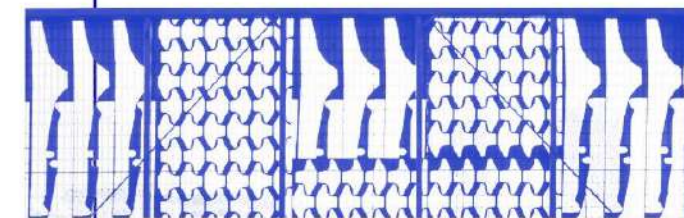
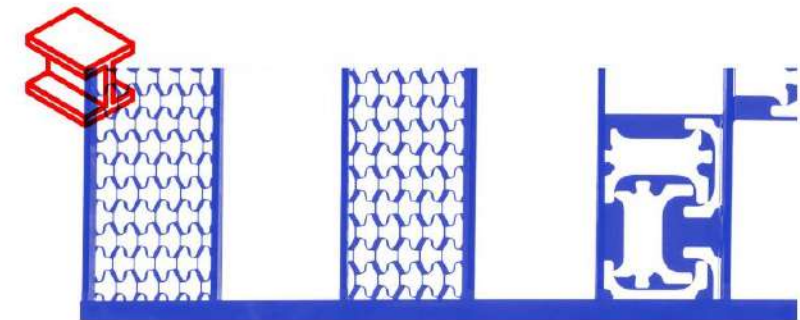





CO₂ emissions steel structure Villa Welpeloo





Brienenoord

SUPERUSE

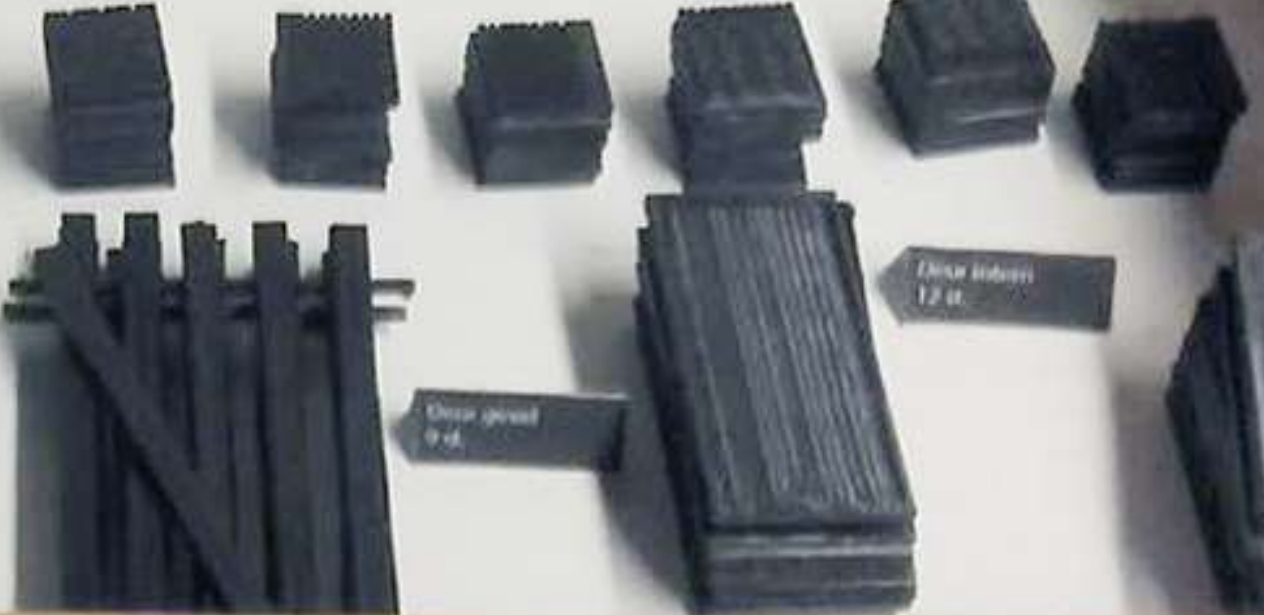
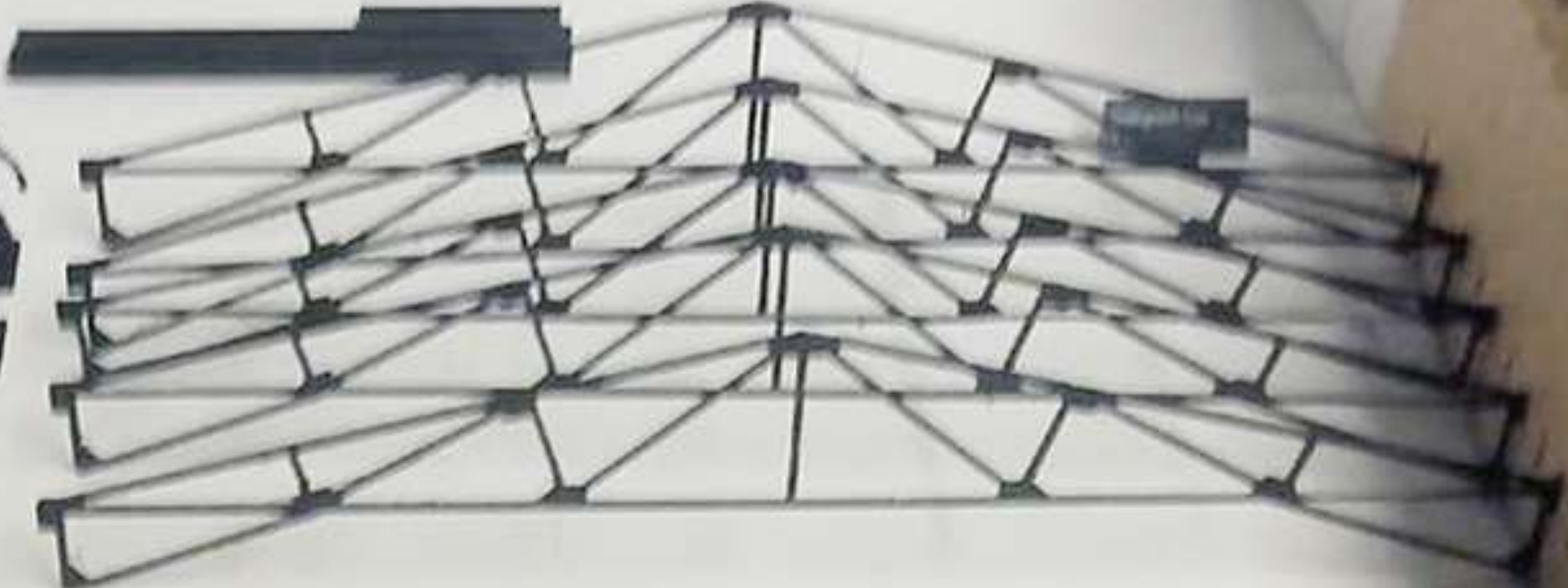

Steel plate 12 x 12

Steel plate 12 x 12

Steel plate 12 x 12

Steel plate 12 x 12

Steel plate 12 x 12

Steel plate 12 x 12

Steel plate 12 x 12

Steel plate 12 x 12

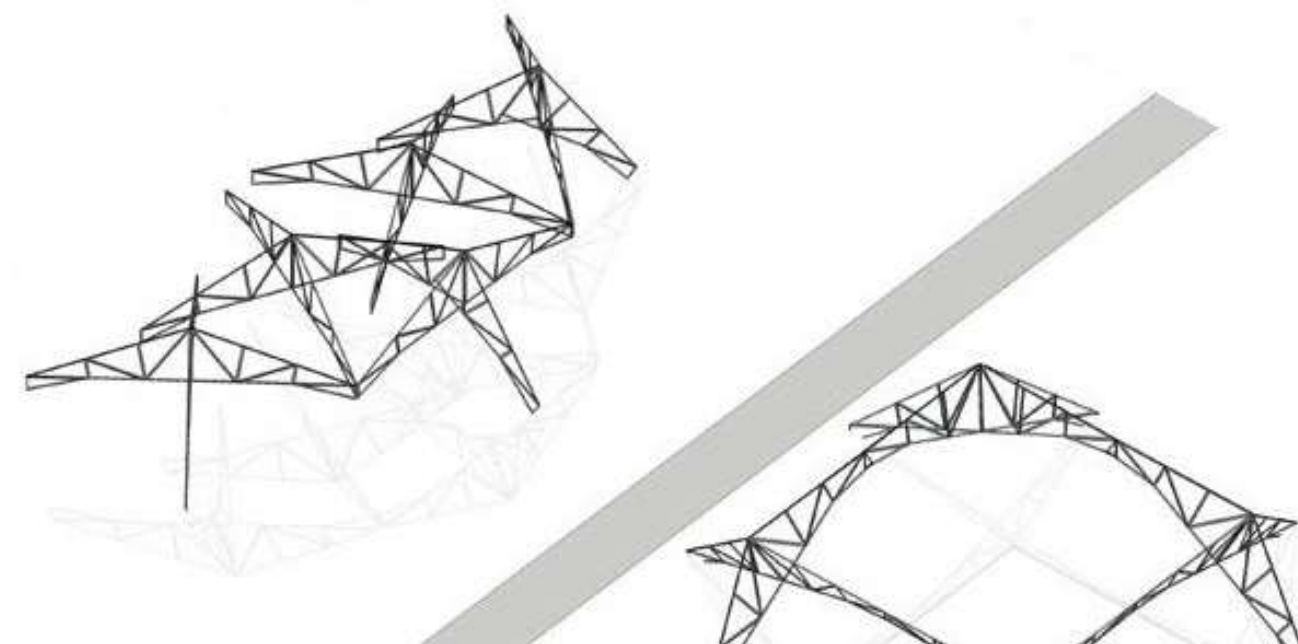

SUPERUSE

Fast life waste

— Materials from fairs, exhibitions, et cetera. Usually of high quality and used for a short period of time with little wear and tear.



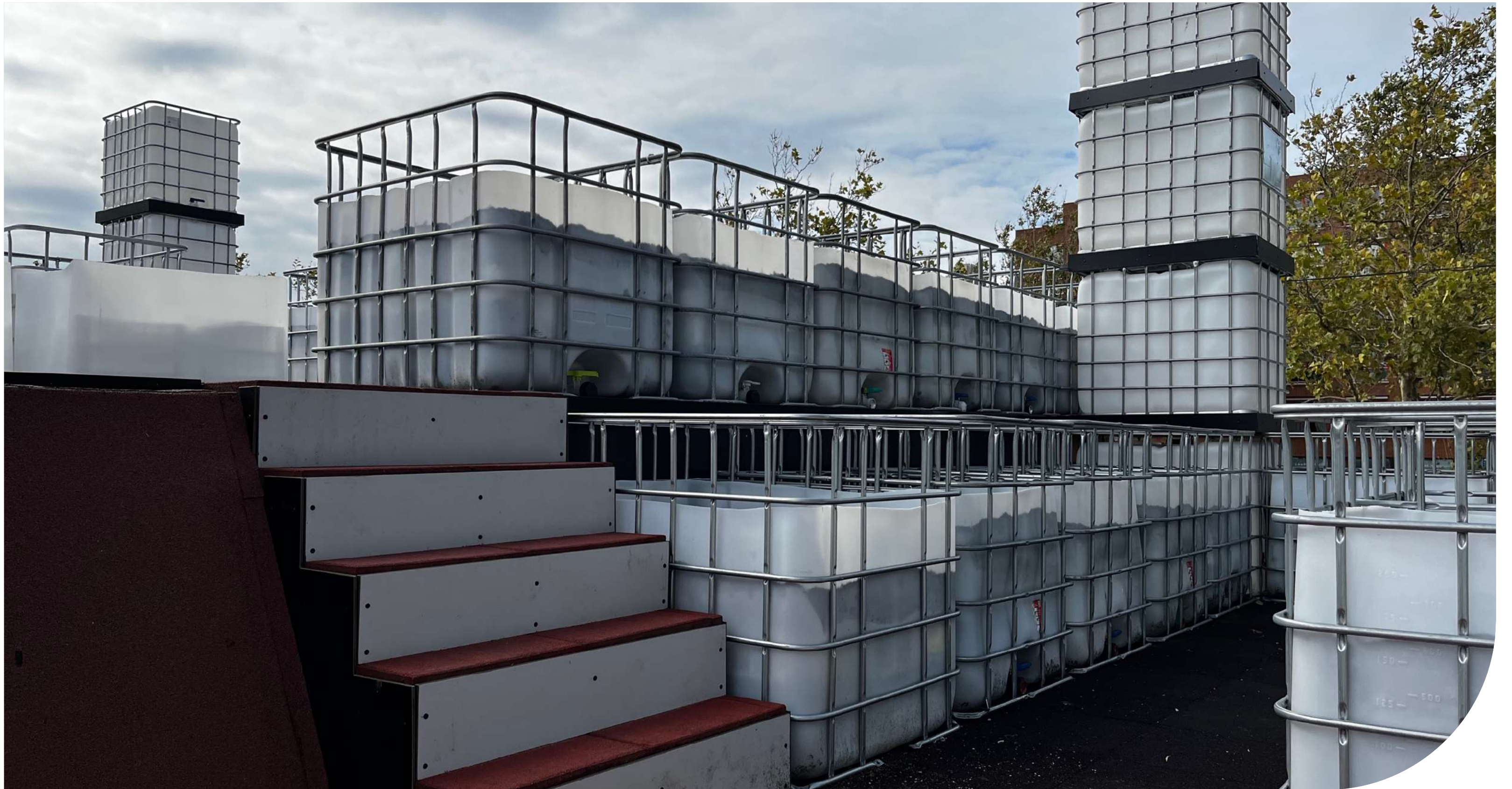



SUPERUSE

Production waste

— Residual materials from industrial production processes, including materials and components that fail quality control.



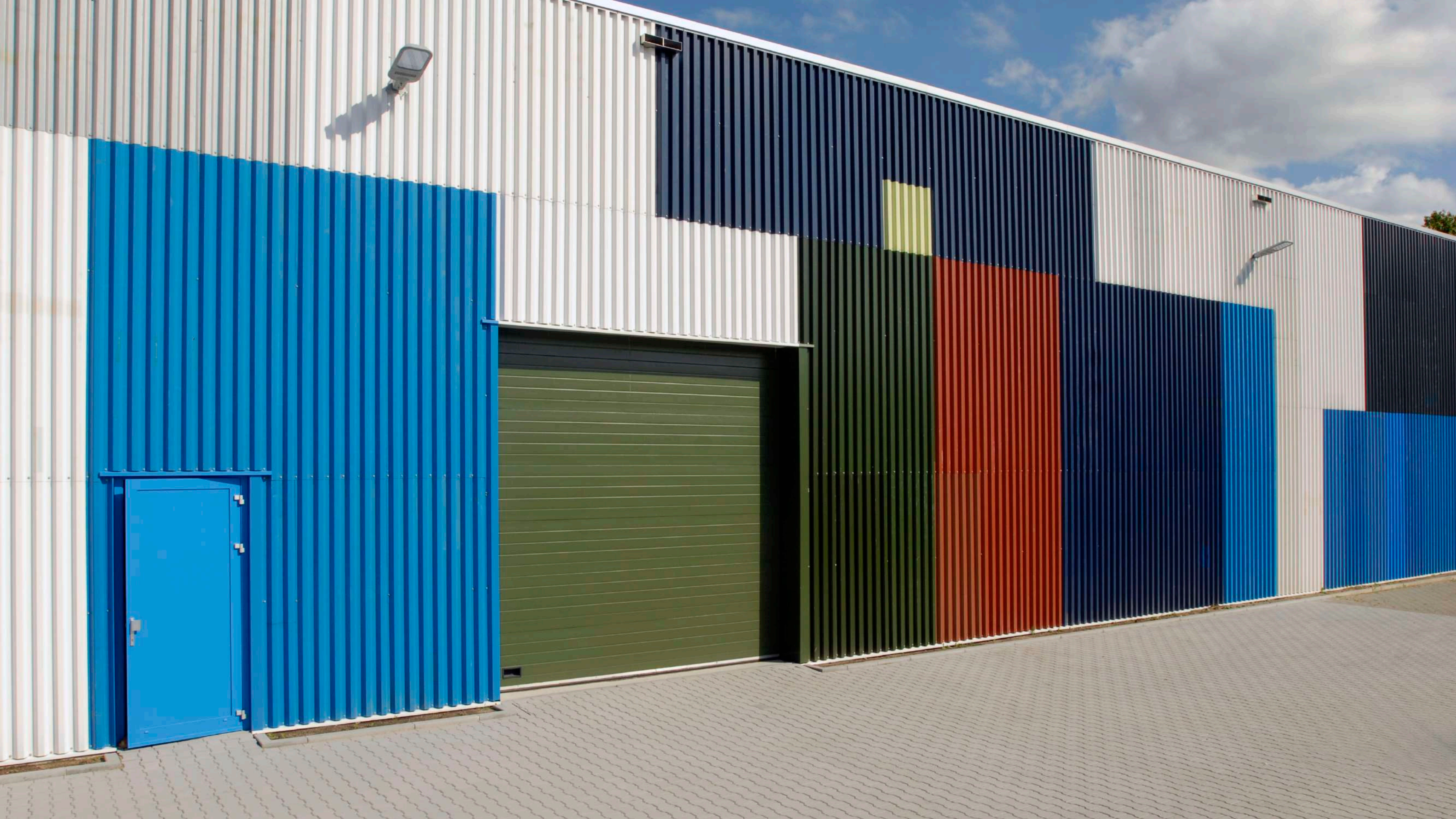





2016

Afvalbrenngstation



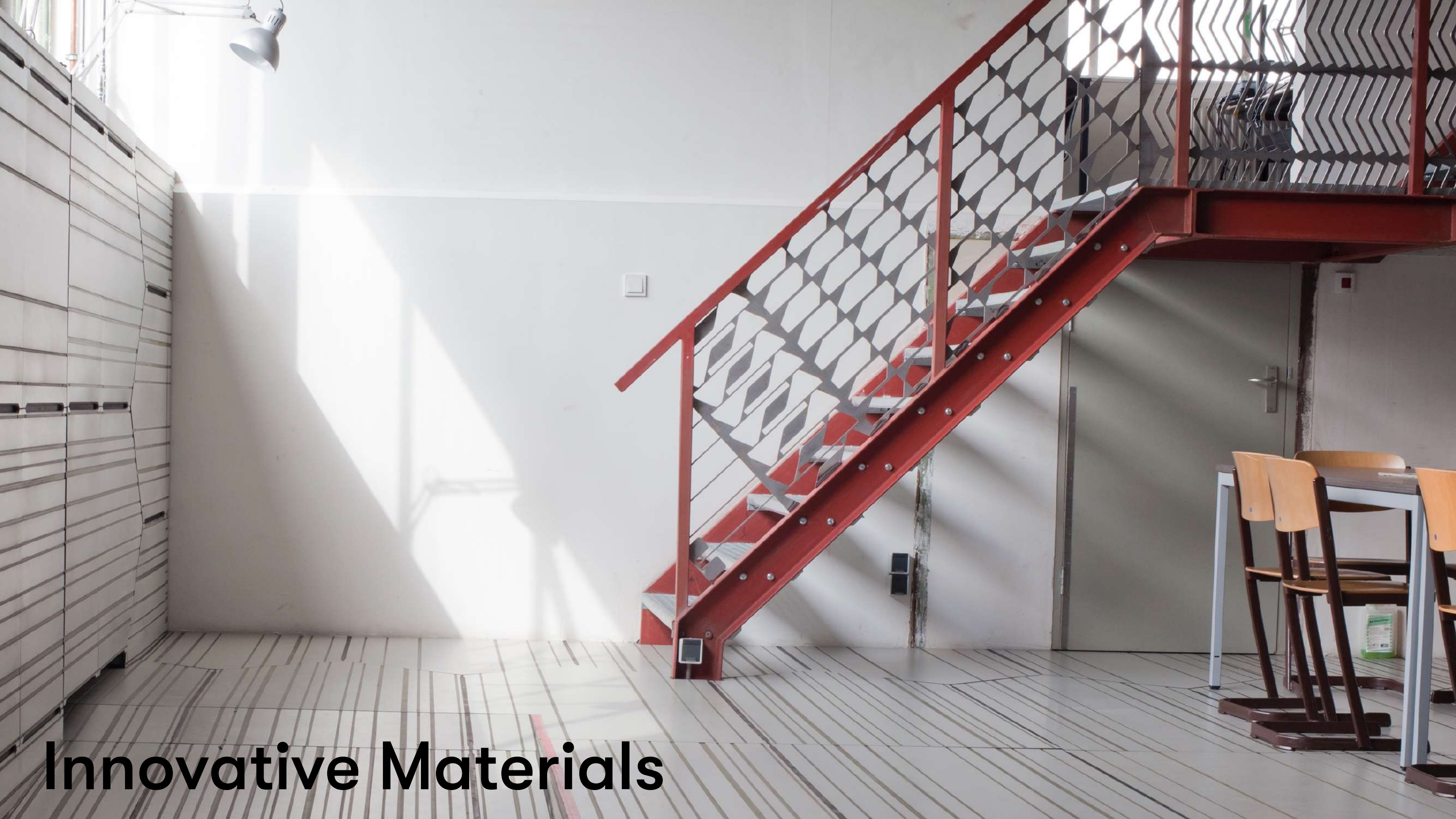

Innovative Materials

SUPERUSE

End of Life

— Material that can no longer be used in its original function due to wear, tear or age.



Miele Ruimtestation



ESTAVISE

110 44

JLL.NL
JONES LE LASALLE





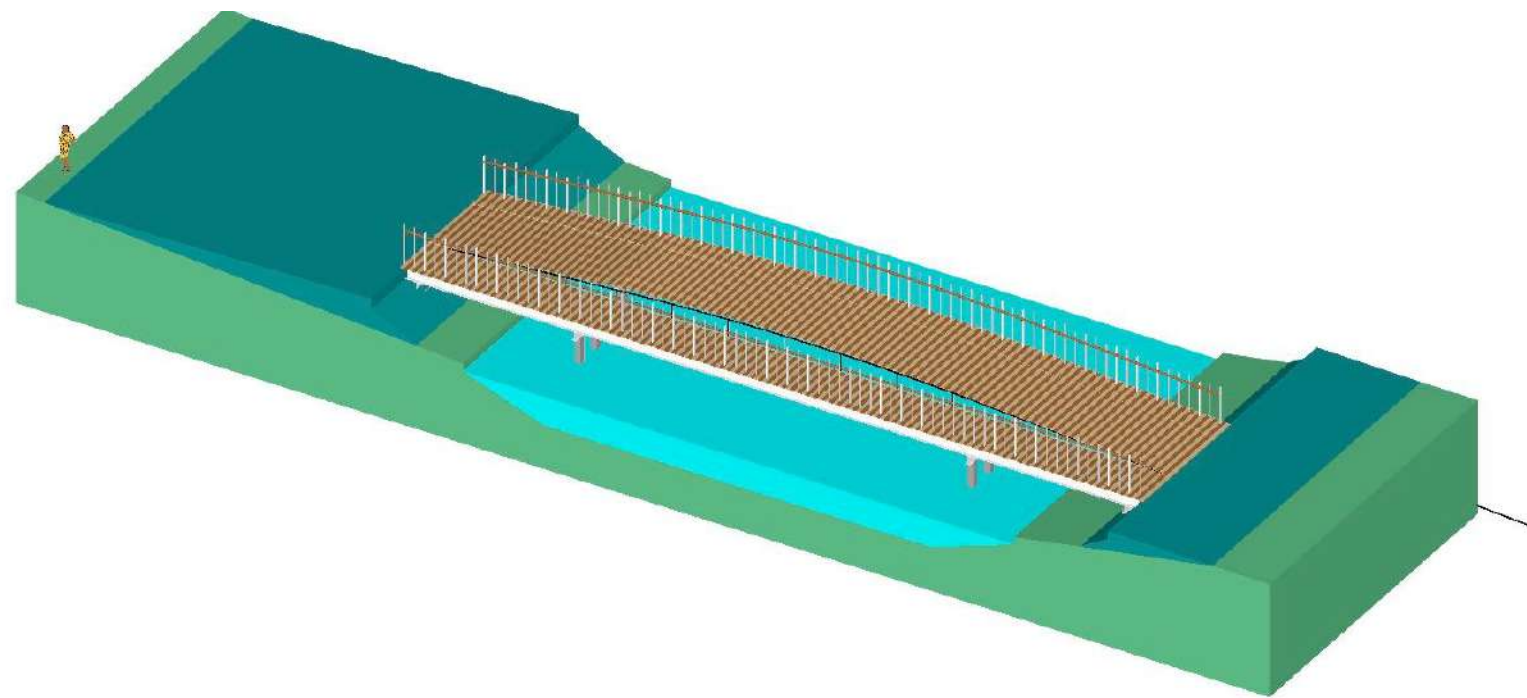

Axonometrie

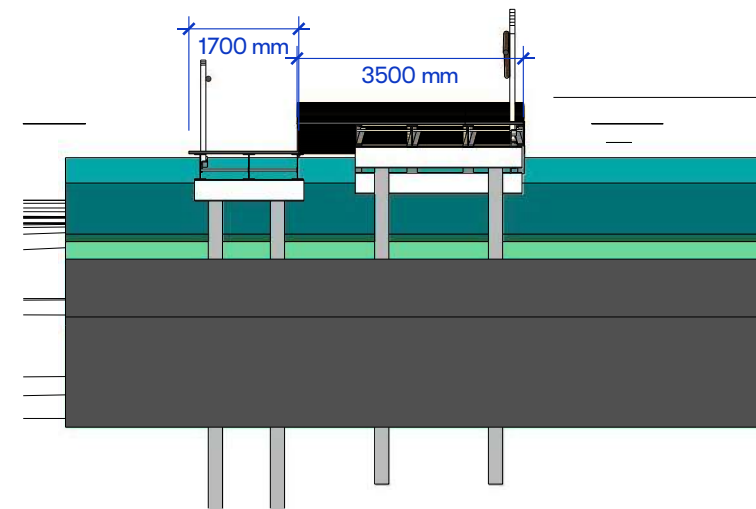

Doorsnede
1:100

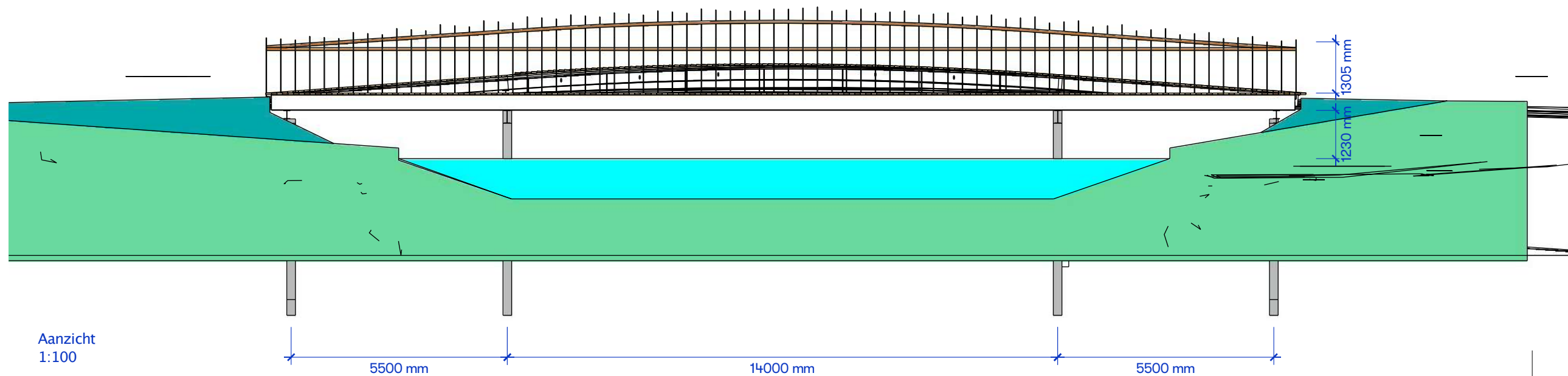

Aanzicht
1:100

SUPERUSE STUDIOS

straat Maasboulevard 100 (BlueCity)
postcode 3063 NS Rotterdam

telefoon +3110 4664 444
e-mail info@superuse-studios.com

Circulaire Langzaamverkeerbrug Amerikavaart

onderwerp

tekeningnummer

-

project
Haarlem brug

schaal / formaat
fase
getekend door

- A3

V
O
T
S
7 september 2023
n.v.t.

projectnummer
XXX.00

opdrachtgever
Gemeente Haarlem

datum
laatste wijziging



LET OP: dit is geen bouwtekening, afmetingen altijd controleren in het werk.

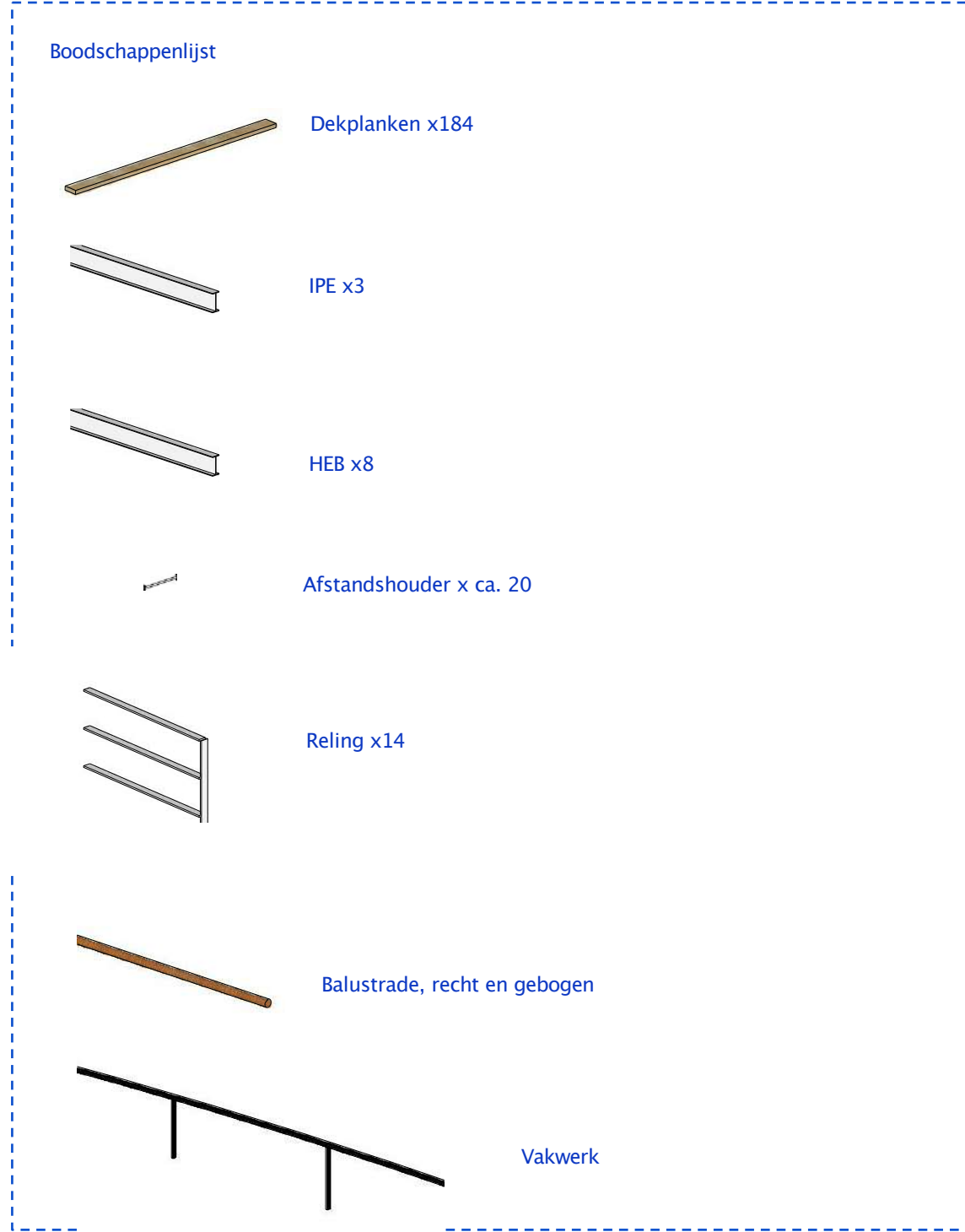
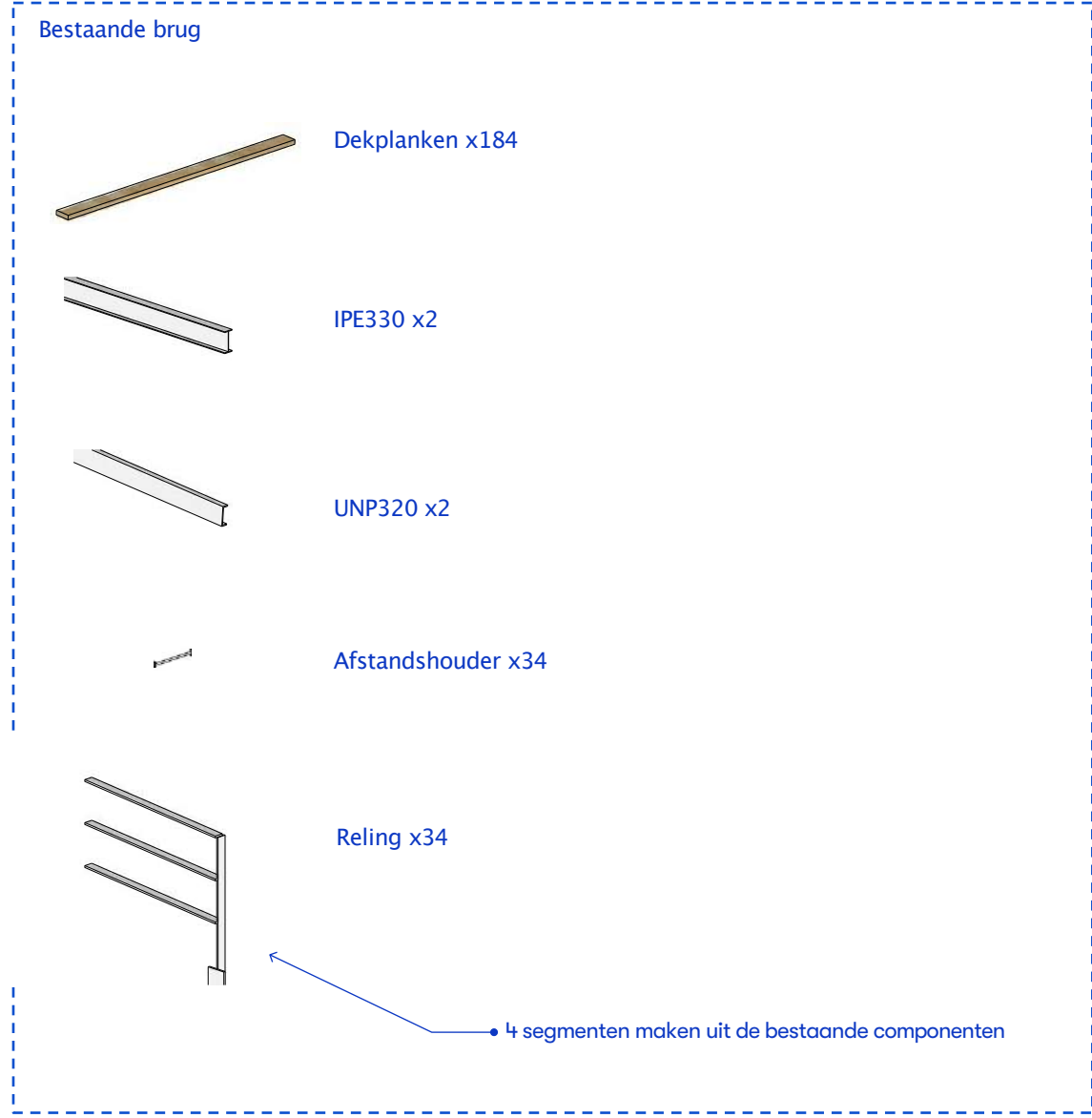

Bestaand Hek
h=1,1m voldoet niet meer

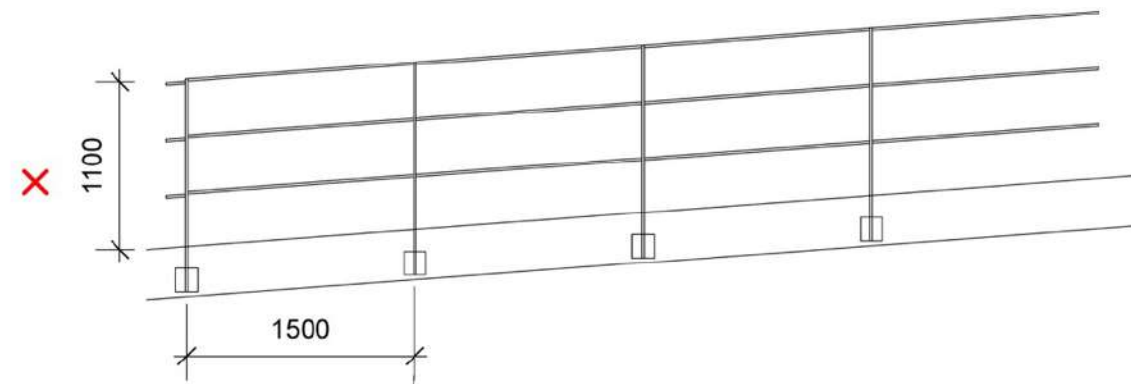

Losknippen

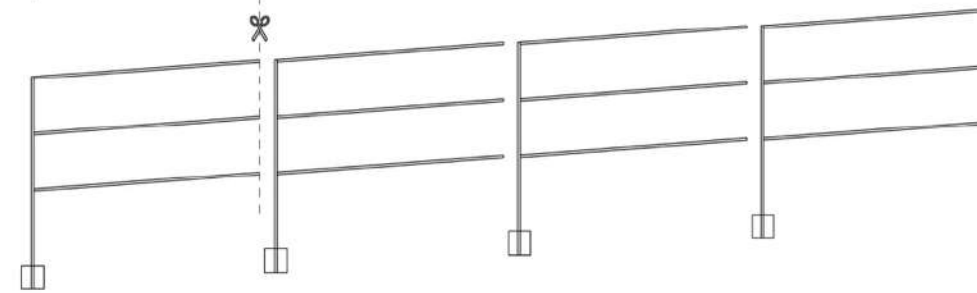

Roteren

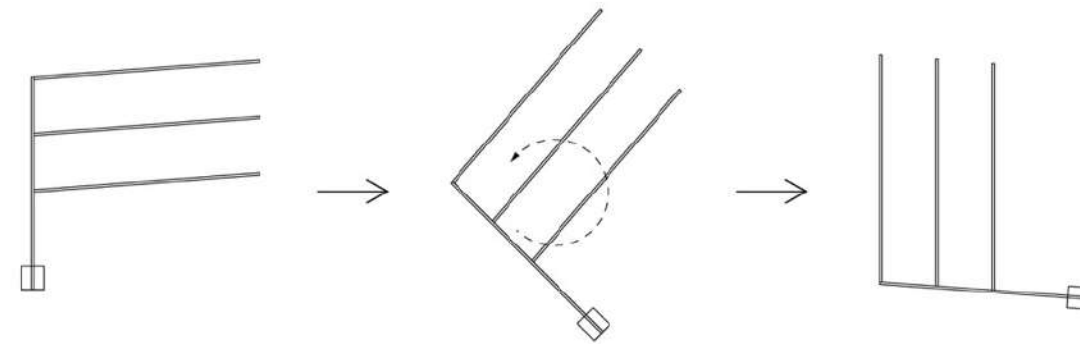

Nieuwe toepassing
h=1,3m nieuwe eis

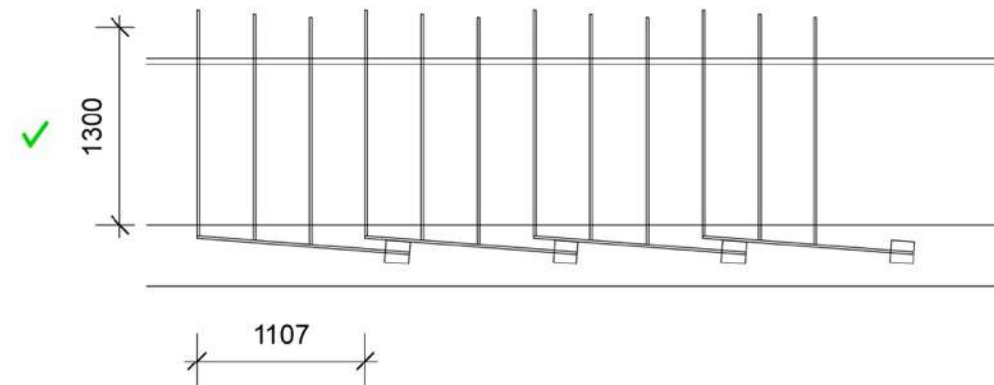

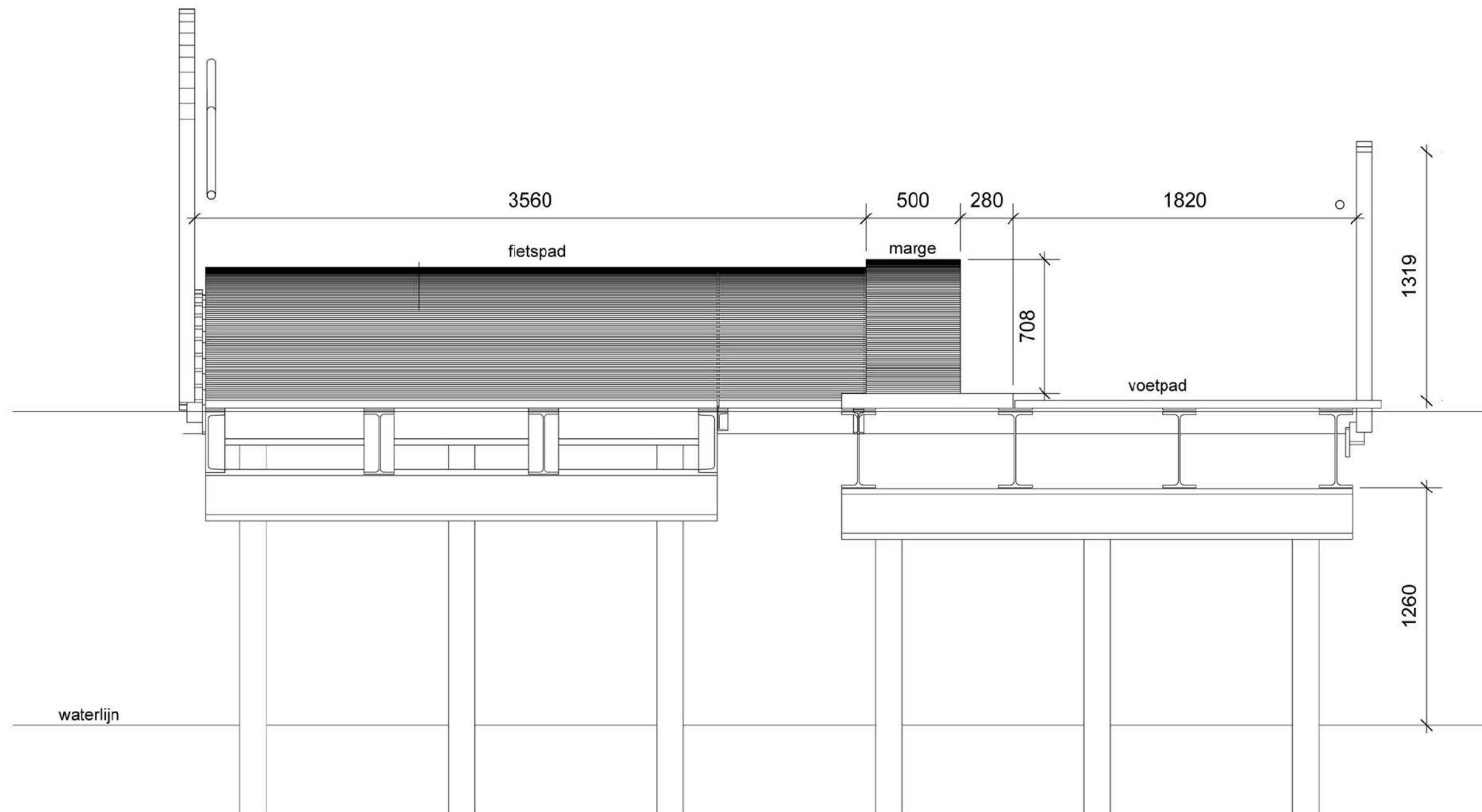

Dit is geen bouwtekening.
altijd in het werk controleren

bestaande brug

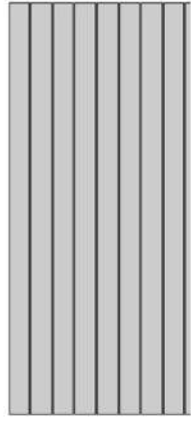

verdubbelen

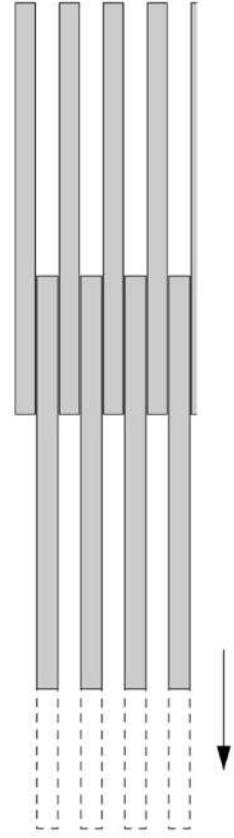

opknippen

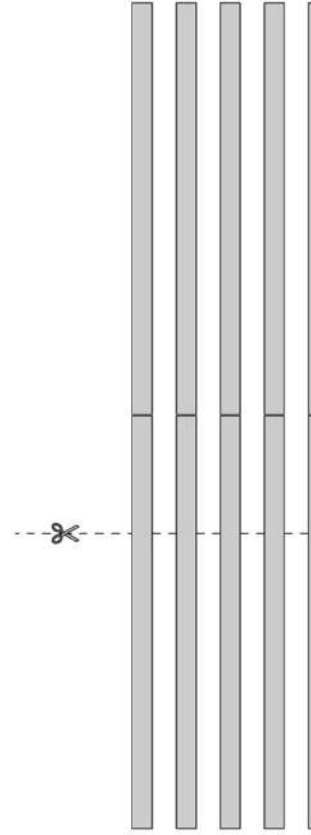

2 verkeersstromen

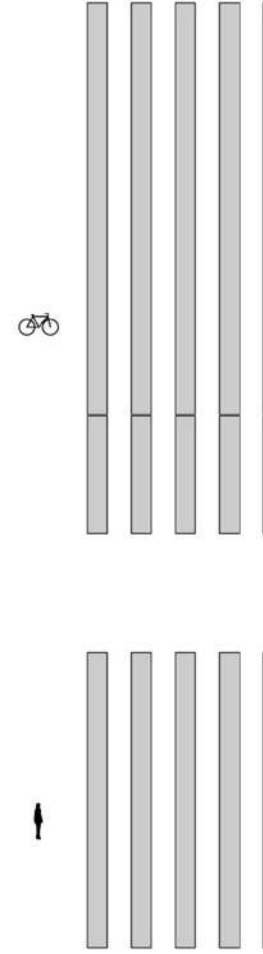

aanvullende latten

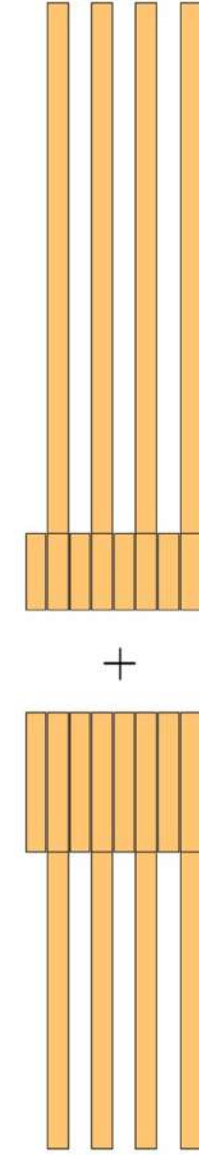

nieuw dek in zebrapatroon

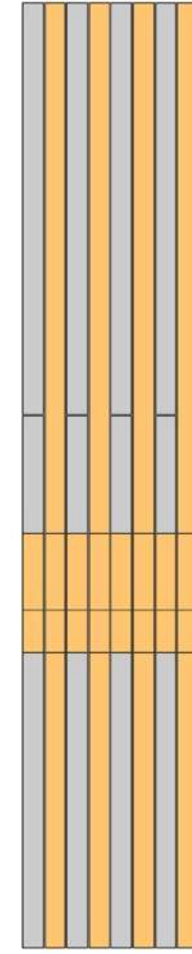



**Beste staalbouwers kom maar op jullie met oogst
en ontwerp vragen**

De toekomst is Superuse en die begint nu!

Vragen?

